



818 thermic cover



819 canopy (for the rain)



824 tray with waist-line

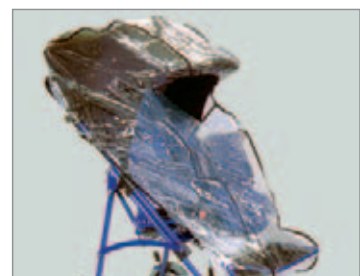

825 rain cover



827 footstraps



828 chest belt



834 padded abduction block



837 tray



852 anatomical headrest



853 vest harness



854 adjustable sunshade



856 feeding base

ORMESA®

JOY



INGLESE - COD. 22076 - 0905

grafica BASTIANELLI Foligno (PG)



JOY

AUTHORIZED DEALER

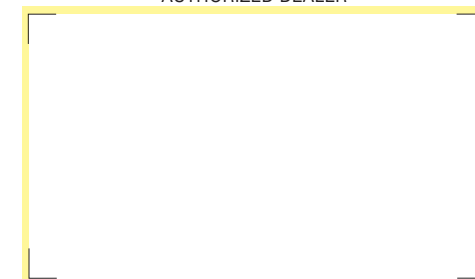

PRODUCT CERTIFIED BY

CERAH
FRANCE



ORMESA® S.r.l

- Via A. Da Sangallo, 1 - PACIANA
06034 FOLIGNO (PG) ITALY - TEL. +39 0742 22927 (r.a.) FAX +39 0742 22637
E-mail: info@ormesa.com - http://www.ormesa.com



COMPANY
WITH QUALITY MANAGEMENT
SYSTEM CERTIFIED BY DNV
=ISO 9001:2000=

Areha ASSOCIATION OF MANUFACTURERS
OF REHABILITATION EQUIPMENT



JOY

A comfortable pediatric positioning push-chair which accomodates the child's growth

technical features

► Two components: closed frame and seat with adjustable dimensions (width, depth) in order to normalize incorrect postural alignments.

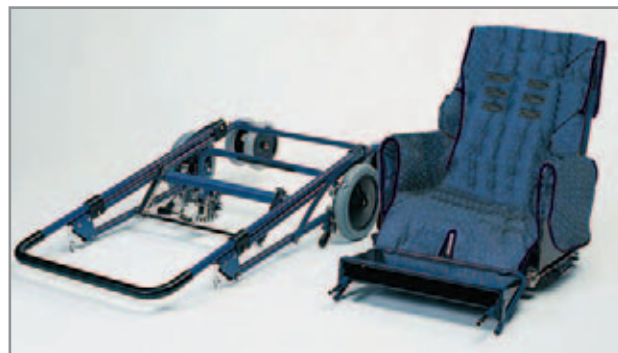

► Seat with three recline positions from 5; to 20; in both directions. Hold the seat and use your foot to lock and unlock the adjustment mechanism. This is a great safety for the child.



► Seat with quick release mechanism frame attachment, facing forwards with recline seat, backrest and footrest.



► Seat in the rear facing configuration to have a complete control and interaction with the child.



adjustable **handlebar**

adjustable **legrest** in 5 different positions

quick release mechanism to **adjust height of footrest**

tip-up **footrest**

6" (15 cm.) diam. **castor wheels** with **solid tyres**

adjustable seat **recline** and **tilt** in three inclinations and in both directions. **safety lock mechanism**

Steel folding frame with non-toxic epoxy varnish

holes to insert sunshade 854

lock mechanism to close and open the frame

Backrest adjustable in 4 positions thanks to a quick release mechanism

release mechanism between seat and frame thanks to a safety lock mechanism

independent **brakes**

8" (20cm.) diam. **wheels** with **solid tyres**

solid hubs

Removable **cushion** is included

Please read the handbook supplied with the push-chair for the technical and functional specifications

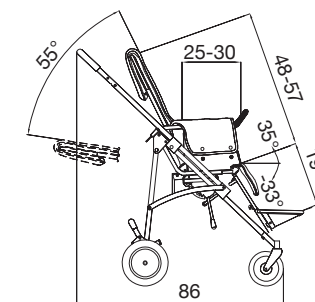
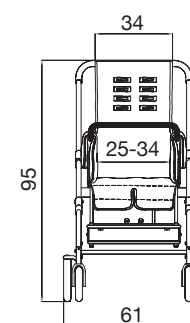

Folded seat unit

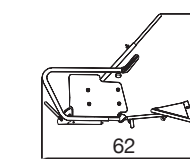

Folded frame without seat unit

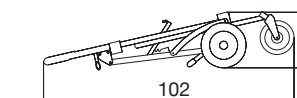

holes to insert vest harness 853

Holes to insert chest belt

adjustable seat depth

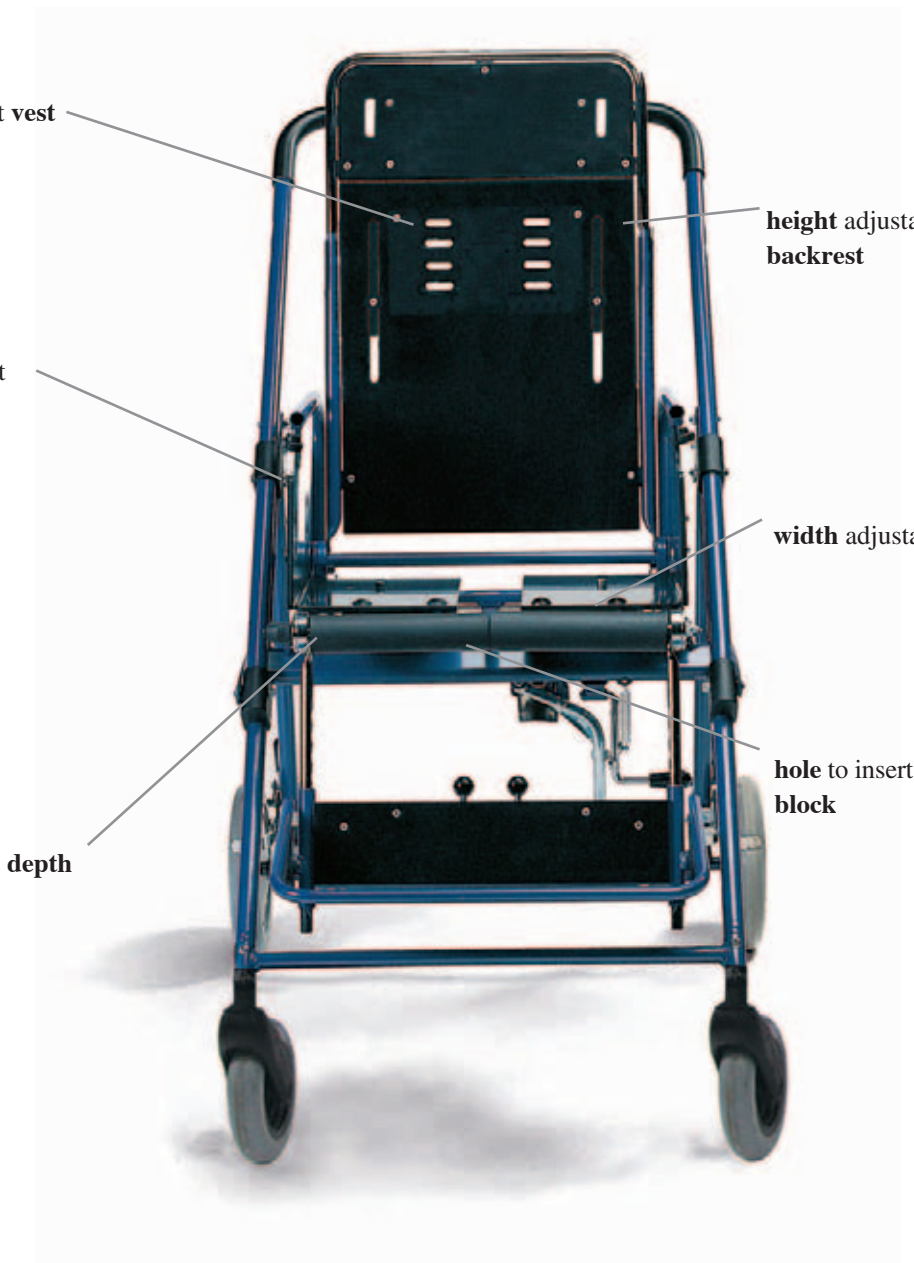

height adjustable backrest

width adjustable sides

hole to insert **abduction block**

Weight 18,6 kg.

Frame weight 9,5 kg

Weight of the seat unit 9,1 kg

Max load 60 kg