



User manual



OPair

Van Raam
Guldenweg 23
7051 HT Varsseveld, The Netherlands

☎ +31 (0)315 – 25 73 70

✉ info@vanraam.com

🌐 www.vanraam.com



Version 21.07

Table of contents

Manufacturer contact details.....	3
Conformity.....	3
Introduction.....	3
Delivery.....	4
Indication.....	4
Safety measures.....	5
Adjustment of the tricycle.....	6
Before the first use.....	12
Electro system Silent.....	19
Van Raam E-Bike App.....	29
Accessories.....	31
Technical specifications.....	36
Maintenance and adjustments by owner.....	37
Repair and maintenance by your dealer.....	39
Adjustments by dealer.....	40
Disposal.....	42
Handover/sale to a new owner.....	43
Guarantee.....	43
Frame number.....	44
Service record, maintenance, modifications and warranty claims.....	45
Delivery and service form.....	51

Manufacturer contact details

Van Raam
Guldenweg 23
7051 HT Varsseveld, The Netherlands

 +31 (0)315 – 25 73 70

 info@vanraam.com

 www.vanraam.com

Conformity

Van Raam declares as manufacturer that the OPair3 tricycle, as described in this manual, has been produced in accordance with the Medical Devices Regulation (EU) 2017/745, risk category 1. All products have been produced in accordance with the 2006/42/EG guidelines. The signed declaration of conformity can be found on the Van Raam website.

Introduction

This user manual provides important and necessary information about the use of your tricycle. We ask you to read this manual thoroughly before using the tricycle. Always follow the instructions as provided in this user manual and keep the manual carefully. The most current version of the user manual can be found on the product page of the bicycle on the website www.vanraam.com.



READ CAREFULLY

Delivery

The delivery should include the following:

- Tricycle with packaging
- User manual(s)
- Possible Smart-battery including card with 5-digit code (depending on options)
- Possible chargers (depending on options)
- (Spare) keys

Check the delivery immediately after receiving it. In case of damage or incomplete delivery we ask you to contact your dealer immediately. Upon delivery you should fill out the form "Form service, maintenance, modifications a warranty claims" in the back of this manual..

Indication

The OPair3 is designed for cycling with children or adults who are unable to ride independently as a result of their disability. If the user is in a wheelchair, then a transfer to the bike should be possible.

Intended usage

The tricycle has been designed for normal use on a flat, solid surface. In general, tricycle caution should always be observed when using the tricycle. Moreover, the safety instructions as described in this manual should be explicitly followed. Local traffic laws and regulations should also be observed.

The tricycle is designed for two people, one in the front (in the wheelchair section) and one rider. The rider must be independently mobile and may not have any serious visual or other restrictions which prevent responsible participation in traffic. The maximum weight of the rider, passenger and carrier load (to be found in the chapter '**Technical specifications**') may not be exceeded.

The manufacturer is not responsible for any damage or injury caused as a result of or during the course of any other type of use.

Safety measures

- Ensure the tricycle is in good condition each time before using it. Check before **each** ride that the brakes are in order. Check the lighting and make sure there is enough tyre pressure.
- Regularly check if the wheels, the handlebars and the saddle are properly fixed and also whether all screw joints are tight.
- Only use the tricycle on a **solid and level surface** (or: not for off-road use).
- A tricycle is sensitive to tipping when riding across a speed bump. Therefore, it is important to always drive straight towards a speed bump.
- Make sure that wide trousers or loose hanging clothing don't get caught in the chain, spokes or pedals.
- Do not use a pressure washer or a steam cleaner for the cleaning of the tricycle.
- Block the tricycle to stop it from moving when you are getting on or off the tricycle. Do this by using the parking brake and holding the tricycle.
- Always lock the tricycle when leaving it unattended.
- Prevent cycling without a passenger as much as possible. The tricycle will behave differently, which may lead to instability.
- Make sure that you do not reach a dangerous speed when driving downhill and entering tunnels. Brake in time and bike at a moderate speed.
- In case of pregnancy, extra care is required owing to a higher risk of injury.
- Do not leave the tricycle in direct sunlight: the temperature of some parts could exceed 41°C resulting in possible burns to the skin.
- If your tricycle is equipped with the Silent electric motor system, make sure that you get used to riding with the electric support engaged. Be careful when you turn on the electric support system and make sure you don't get startled by unexpected behaviour because you turned on the electric support.

Load

The maximum load should not be exceeded. See the information in the technical data table in the **'Technical Specifications'** section of the user manual. By permitted load we mean the total load, including the load on the luggage rack.

Make sure that the permitted load on the luggage is not exceeded. (**maximum** 20 kg). People may not be transported on the luggage rack.

Damaged or worn out parts

The replacement and repair of parts (frame, forks, light, brakes, drive mechanism and the handlebars) should **always** be performed by an authorised dealer. If not, the guarantee ceases to be valid and you will be personally responsible in the event of possible damage.



Specific safety parts should **always** be replaced by new parts!

Adjustment of the tricycle

Before using the tricycle, adjust its height to the height of the rider. This is of essential importance, especially with regard to the, saddle, handlebars and seat.



If an optimum setup with specified instructions is not possible you can contact your dealer for a suitable solution.

The brakes are always properly adjusted and may only be adjusted during regular maintenance by your dealer.



Take care that fingers and limbs do not get trapped while adjusting the tricycle.

Saddle Height

You can correctly set the saddle height by sitting on the bike and placing your foot on the pedal in the lowest position. Make sure your leg is stretched, yet still relaxed.

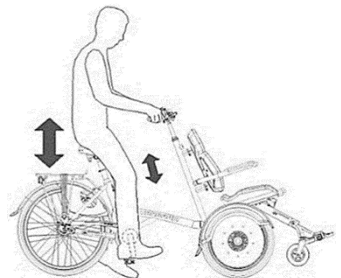

To adjust the saddle:

1. Open the quick-clamp [A].
2. Slide the saddle to the correct height.
3. Close the quick-clamp.

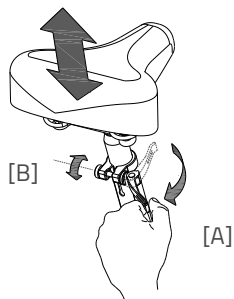

Make sure clothing cannot get caught in the clamp!



If the clamp closes too easily, the clamping force is too low. In this case, open the clamp and tighten the nut [B] a bit more. If a lot of force is necessary to close the clamp, the nut should be loosened slightly.



Don't **pull out** the seat post further than the markings. If you do so, the tube won't be inserted deep enough into the shaft, increasing the risk of breakage, which may lead to serious injuries.



Handlebars height

The height of the handlebars greatly influences ride comfort. It determines the pressure on the hands and posture of the back. You decide the most comfortable position yourself with some practice.

To adjust the handlebar:

1. Loosen the screw with an Allen key.
2. Slide the handlebars stem to the desired height and then firmly tighten the screw

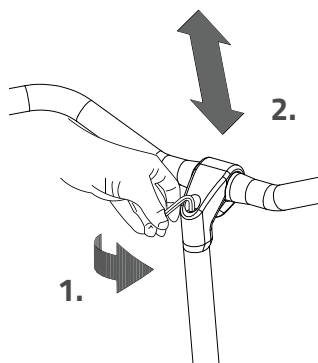



Do not **slide the** handlebars stem further than the markings. If you do so, the tube won't be inserted deep enough into the shaft, increasing the risk of breakage, which may lead to serious injuries.



Steering Position

You can tilt the handlebar. This affects the distance from the handlebars to the upper body. Feel free to determine what setting is most comfortable for you.

To tilt the handlebar:

1. Loosen the screw using an Allen key.
2. Place the handlebars in the desired position and firmly tighten the screw.

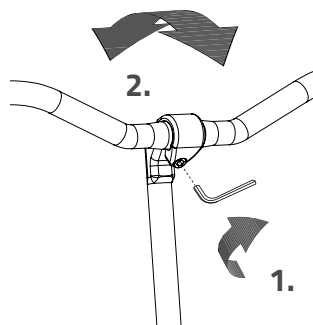

Seat depth

Adjust the seat depth to the passenger. Adjust the seat to the desired position.

To do this:

1. Unscrew the four screws with Allen key.
2. Slide the seating in the desired position and tighten the four screws.

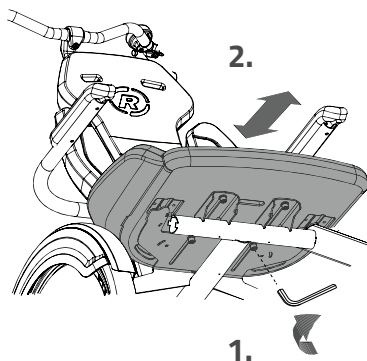

Chair Backrest

Adjust the position of the backrest and side supports to the passenger.

Adjust the backrest to the desired position. To do this:

1. Loosen the screw of the top and/or bottom bar with an Allen key.
2. Turn the backrest to such a position that the passenger feels comfortable. Now tighten the screws.

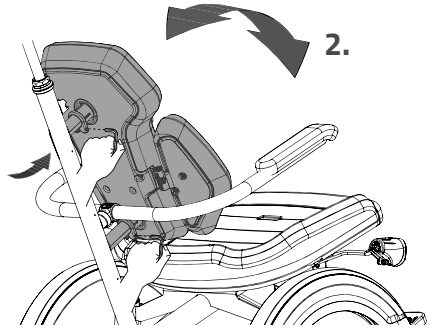

Adjust the width of the side supports.

To do this:

1. Loosen the two backrest screws and two side support screws with an Allen key.
2. Slide the side supports to the passenger's desired position. Now tighten the screws.

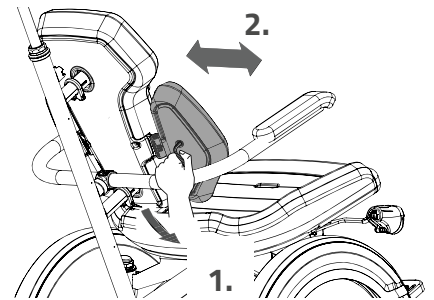

Finish by adjusting the angle of the side supports.

To do this:

1. Loosen the screw with an Allen key.
2. Turn the side supports against the body, so that the passenger is comfortable.
Now tighten the screw.

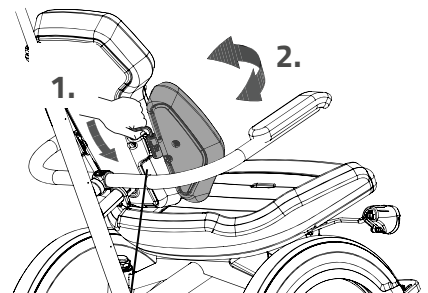

The neutral position of the side supports is indicated by the markings [A]. They can also be used to place both side supports in a similar position.

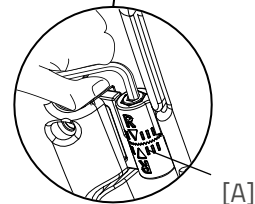

Footplates

Adjust the position of the footplates to the passenger.

1. To adjust the height of the footplate:
First determine whether the footplates are in the right position. This depends on the leg length of the passenger.
Loosen the screw with an Allen key. The footplates can now be slide out and be put in the correct position.
Make sure that the legs are at an angle of 90 degrees. Now tighten the screw.
2. To adjust the angle of the footplate:
Loosen the screw with an Allen key and place the rest in the desired position as indicated by the passenger.
Now tighten the screw.
3. The neutral position is indicated by markings [A]. This so you will know when both footplates are set to the same position
4. The footplates can be folded when mounting and dismounting.

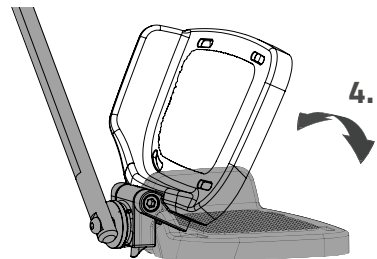
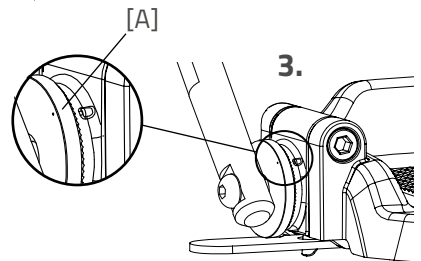
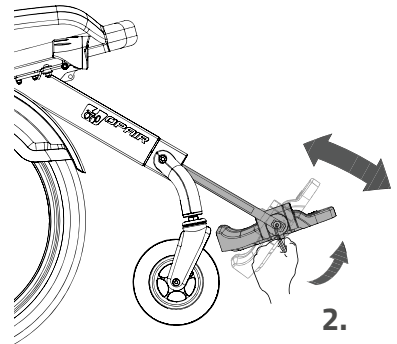
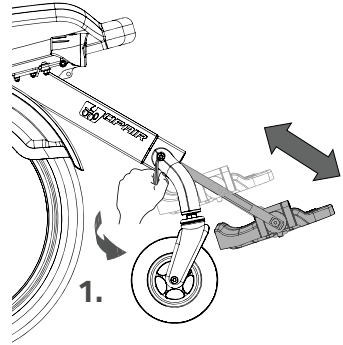

Chair Hip Belt

Wrap the belt around the body and snap it into the clamp. You can remove the seat belt again by pressing the red button.

Adjust the belt length to the passenger by following these steps:

1. Open the belt clamp on the bottom of the seat.
2. Pull the belt so that it covers the body of the passenger. Now close the belt clamp.

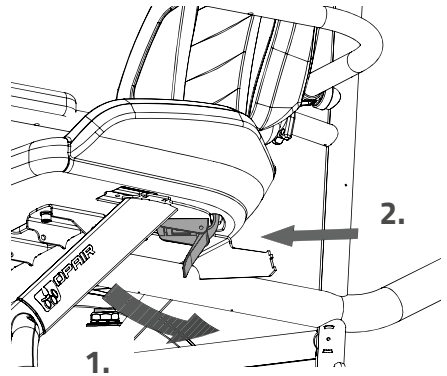
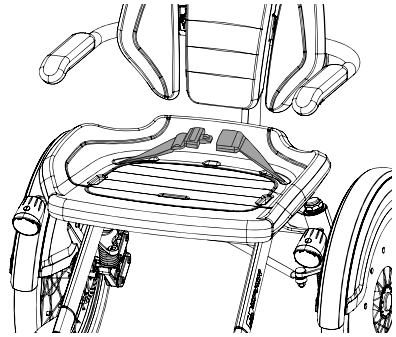

Before the first use

Parking brake

Always use the parking brake if you park the tricycle and leave it behind.

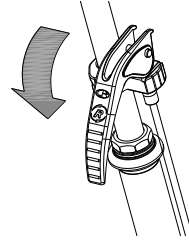

Block the tricycle with the hydro brake when passengers are getting on and off.

To operate the parking brake, squeeze the left brake [A] and secure the brake with the lever [B].

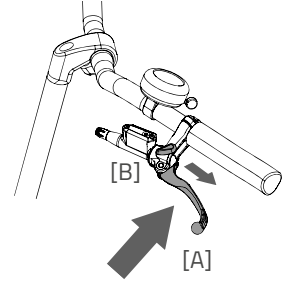

Always try to park the tricycle on a level surface. The tricycle may never be parked on a slope bigger than 6 degrees.

Lighting

Normally, the lighting on your bike can be operated manually and set to different modes. However, if your bike is equipped with the Silent Elektro system, your lighting will automatically turn off when the electric system is activated. The controls of both the manually operated and centrally operated lighting is explained below.

Manually operated headlight

The front light has a pressure switch with three settings: **On/Auto/Off**.

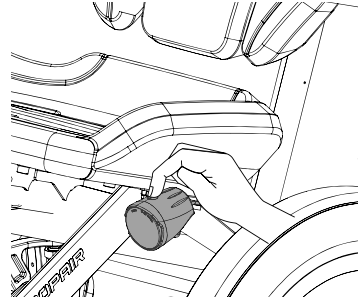

By pressing the pressure switch once, the front light will turn on. By pressing again the lamp will switch to 'Auto' mode (a green LED will flash for 5 minutes). Finally, a third press will turn the front light off.

Auto "on" feature:

The front light will automatically turn (as long as it is in 'Auto' mode) on when it is dark, the light sensor is activated and the tricycle is in motion.

Auto "off" feature:

The front light will automatically turn off after 4.5 minutes without motion in 'Auto' mode. The light will first dim from 100% to 50% and then completely turn off.

Adjust the angle of the front light so that the centre of the light beam is located approximately ten metres in front of the tricycle.

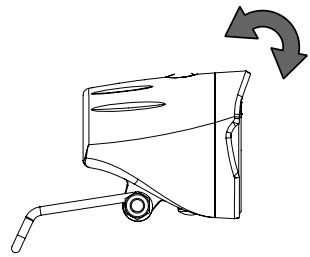

Under the pressure switch on the top of the front light is a battery indicator that lights up when the batteries are low. Once the battery indicator starts lighting up red, replace the batteries as soon as possible.

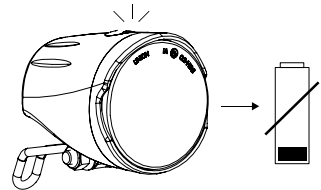

The light comes with 4 pre-installed AAA alkaline batteries. Before use, remove the plastic strip that protects the batteries.

Follows the steps below to replace the batteries.

1. Remove the screw on the bottom of the front light with a screwdriver.

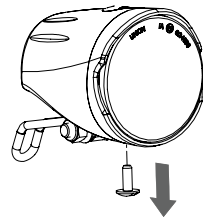

2. Remove the front cover by turning it slightly and pulling it forward.

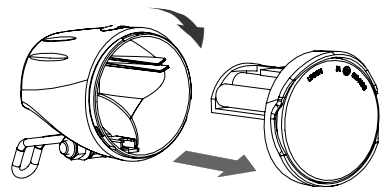

3. Replace the alkaline batteries (1.5 V - 1500 mA) and reattach the front cover.

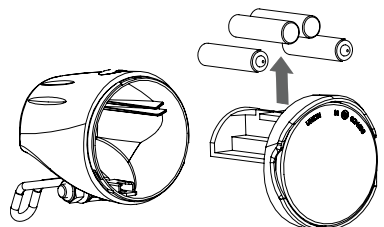



De verlichting alleen bij stilstand bedienen om gevaarlijke situaties en kans op beknelling te voorkomen. Advies: gebruik de automatische stand van de verlichting.

Manually operated rear light

The rear light has three options which you can choose by pressing the button repeatedly: **On-Auto-Off**.

The setting is as follows:

- Press **1x**: light is on
- Press **2x**: lighting is automatic
- Press **3x**: light is off

With the "On" or "Off" mode, the rear light can be manually switched on and off.

With the "Automatic" mode the rear light automatically turns on and off with the help of light and movement sensors. When the tricycle stands still for a while, the light will automatically turn off.

The rear light works on batteries. When the batteries are almost empty, a red LED light on the top starts flashing. To replace the batteries, follow the next steps.

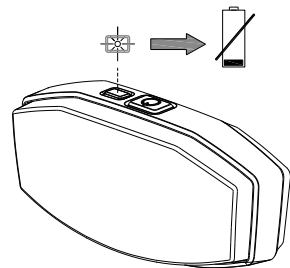
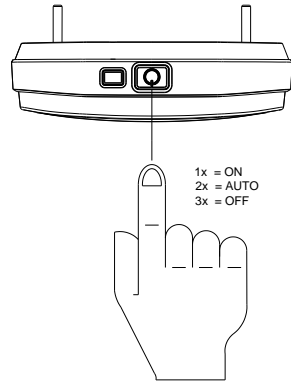

1. Dismantle the cover of the holder by pressing in the lip at the bottom of the light.

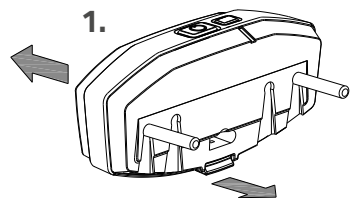

2. Replace the alkaline batteries (1,5 V - 1500 mA) and assemble the cover.

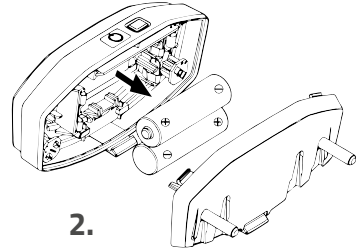

*Batteries cause environmental pollution.
Follow the local regulations during disposal.*

Centrally Operated Lighting

The bike has been equipped with centrally operated lighting, with the lighting being connected to the electric system.

The lighting will turn on automatically when the electric system is activated.

Adjust the angle of the headlight, so that the centre of the light beam is aimed about ten metres in front of the bike.

You can manually turn the lighting on and off by briefly pushing the on/off button on the display. When the electric system is turned off, the lighting will turn off automatically.

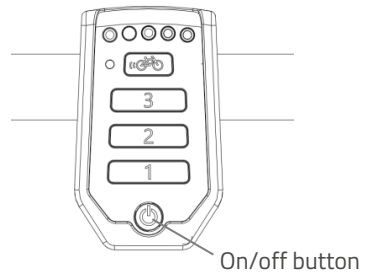
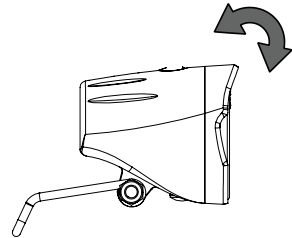

Make sure there is always a battery on the bike when you are cycling after dark!

Once the battery is nearly empty, the motor will no longer provide pedal support power assistance while cycling. The lighting will still be powered by leftover power.

Gears

Your tricycle has eight gears. The gears can be adjusted by turning the handle.

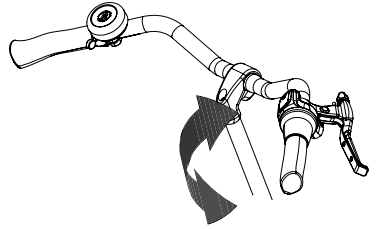

Never pedal when changing gears.

Please note: If your bike has an electric motor at the rear, you must **continue pedalling** when changing gears.



Please note! Do not shift gears and then paddle backwards. This could cause the chain to run off the sprocket.

Before every ride check:

- The brakes (including the parking brake)
- The tyre pressure
- The lighting
- That all parts are secure
- That the battery is sufficiently charged (optional)

Contact your dealer and never use your bike if you notice any irregularities.

As is the case with all mechanical parts, the tricycle is subject to wear and high loads. If a component fails, this may lead to very dangerous situations and damage or injury to the tricycle or user. Any form of cracks, scratches or change of colour in heavily loaded parts of a component is an indication that the part must be replaced.

Points of attention while cycling

Once you've set up the bike on the basis of the rider and passenger's size you can start using the bike.



Your bike is a tricycle. The experience of riding a tricycle is completely different from riding a bicycle with two wheels!

Practice, in particular, with bends and braking, because a tricycle can react contrary to what you would expect. It may happen that the back wheel comes off the ground on the inside when going round a bend. To avoid this the rider leans towards the inside of the bend with his body.

One of the brake levers (usually the right) operates the brake on the front wheel. This deserves special caution, as a forceful braking could block the front wheel, which could result in a fall. The driver should be familiar with controlled braking of the front wheel!



If there is an electric motor on a bike: you must train with the acceleration function and reverse functions. Be careful that the acceleration mode or reverse mode are not unintentionally started while using the bike. For example, at traffic lights the reverse function can accidentally be activated and the tricycle reverses.



High speeds in the bends, driving on rough ground, and sharp bends can lead to the tricycle **falling over!**



The tricycle will behave differently when cycling without a passenger. Try this very carefully the first time!

Important safety precautions for the rider

- Make sure you ride with extreme caution when first using the bike.
- While riding, keep both hands firmly on the handlebars and your feet on the pedals.
- Test the bike's behaviour at an appropriate speed on uneven surfaces. In doing so, you will learn how to respond to unexpected movement of the bike and handlebars.
- Explore how the tilting movement of the tricycle reacts to your posture. Always lean towards the inside of a bend.
- Small obstacles must be traversed at appropriate speeds.

- Obstacles higher than five centimetres must be avoided.
- Make sure not to ride at dangerous speeds when riding downhill. Brake on time and cycle at a moderate speed.

Electro system Silent

The Silent Electric motor system is a special developed support system by Van Raam for the rehabilitation market. The system is characterized by:

1. A simplicity of operation
2. Individually adjustable support for cycling
3. Modern and efficient electronics
4. The powerful electric motors
5. High quality and safe batteries
6. Highly reliable system

The Silent system comes standard with a basic support mode individually programmed for your bike. In most cases, it gives precise and smooth cycling characteristics with a good compromise between support and radius of action.

In special cases, an individually tailor-made cycling program is necessary. You can obtain information from the dealer about the possibilities of a customised cycling program.

Functions:

The electric system has the following functions:

- Pedal support while cycling
- Start support
- Backwards pedalling with support
- Intergrated lighting control

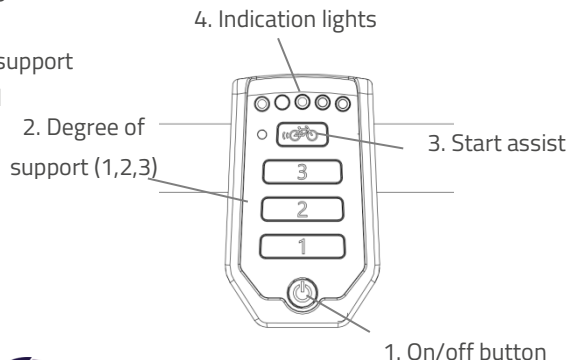

1. On/off button

Using the on/off button, the electrical system can be switched on or off.

- Switching on: Push the button briefly.
- Switching off: Push the button for two seconds.

After the system is turned on, the electric motor is active in level 1.



When the system is not used, it will automatically turn off after a certain time.



Always turn off the electric system before getting on and off the bike, and when you are walking while holding the bike.



Make sure that the switch under the luggage carrier is always pressed toward the side where the battery is located. Note that with some models the battery switch has a middle (neutral) position as well. That means the battery is switched off.

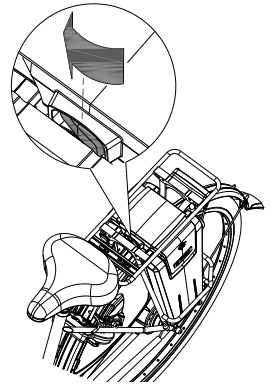

2. Degree of support 1, 2 and 3

The desired support can be set by using one of the support levels 1, 2 or 3.

1. Light support, maximum range.
2. Average support, average range.
3. Maximum support, low range.

You can change the level while cycling.



The behaviour of the battery depends on a lot of different factors and is strongly influenced by: capacity and voltage of the battery, degree of support that is used, temperature, wind speed, tyre pressure, cycling speed, weight of the user and the luggage, use of gearing etcetera.

3. Start assist

The Silent electric motor has a start support. This allows the driver to pull-away without pedalling up to a speed of 6 km/h over six seconds. To accelerate, press the start assist button and keep it pressed down. The function will only activate again, when the support button has been pressed down again. If you peddle normally, the function works for up to six seconds, each time the button is pressed, up to maximum speed of the tricycle (20 km/h).

The start assist is used for:

- Extra support when starting.
- Extra support for cycling uphill.



When cycling a steep climb, you can use support in level 3 and push the start assist repeatedly for six seconds to achieve maximum support.

4. Indication lights

The level of charge in the battery is given by five LED lights: four of these are green, the one on the left can show either green or red, if charge is low.



The battery is fully charged. When in use, the number of green LED lights on the battery will decrease.



The battery is 50% charged when two green LED lights are on.



The battery is almost empty if only the last red LED light is on. The battery needs to be recharged or replaced by a (new) fully charged battery.



When the last red LED light flashes, the battery is empty and the motor will no longer support while cycling. The integrated lighting continues to work.

The battery is equipped with a button and indicator that makes it possible to check the charge by briefly pressing the button [A]. The status of the battery is shown with five green indicator LEDs, of which the left most one can blink. That means the battery is nearly empty. During charging, the battery displays the progress of the charging.

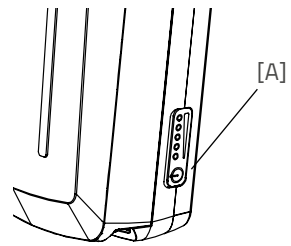

Reverse mode

The reverse mode is activated by pedalling backwards from a standing position. Within a few seconds the motor is activated and the tricycle cycles at a speed of about 2 km/h backwards (when you start to pedal backwards).



Do not be startled by an unexpected reaction from the electrical system. If you e.g. wait for the traffic light and you play with the pedals by moving them backwards the reverse mode is activated and the tricycle cycles backwards.

Centrally Operated Lighting

The bike is equipped with centrally operated lighting, with the lighting automatically turning on when the electric system is activated. Further instructions can be found in the chapter '**Before the first use**'.

Other functions

The smart display has an automatic dimming function. With an inbuilt light sensor the lights of the display will automatically creating less distraction for the cyclist in darker or more shadowy conditions.

Charging the Battery

For the best performance and to prolong the life of the battery, we recommend that you charge the battery at home at room temperature.



Only use the charger if the temperature of the environment is between 0 and 35 degrees centigrade.

To charge the battery:

1. Unlock the battery by turning the key a quarter.
2. Pull the handle forward.
3. Take the battery pack from the holder.
4. Take the battery pack inside. **First** plug the charger into the socket. The green LED will light up. The charger is now on standby.
5. **Then** insert the charging connector of the charger into the charging point of the battery. The red LED will light up. The charger is now charging.



Please note! If the battery is not connected properly, the green LED will light up (standby mode). If the connection is poor, unplug the plug from the socket and clean the charger's connector with a dry cloth.

6. Depending on the battery level, the charging time is about 2,5 hours with a 13,6 Ah/36 V battery.
7. Once the battery is fully charged, the green LED will be solid. Now **first** remove the charging connector of the charger from the connector of the battery.
8. **Then** unplug the charger from the socket.

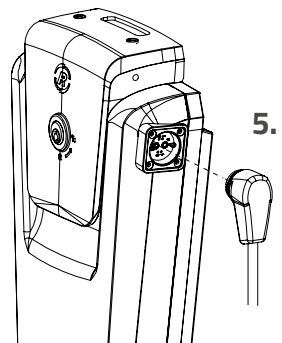
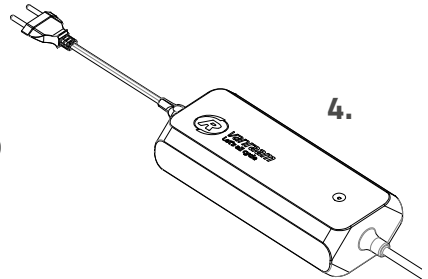
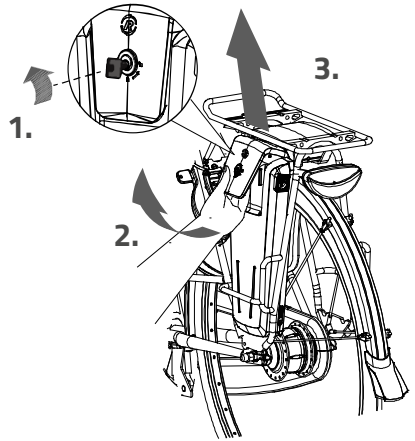

9. Put the battery back in the holder of the cycle. Slide it behind bar [A] and press it firmly on strip [B].
10. Pull the handle backwards and push the top of the battery to connect as shown in the drawing and close the lock.
11. Push the handle forward and close the lock.

It is also possible to charge the battery while it is still in the holder.

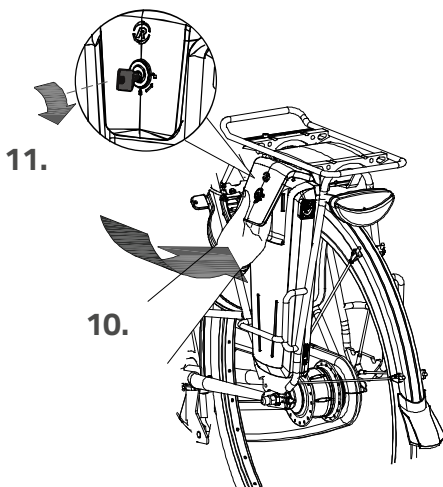
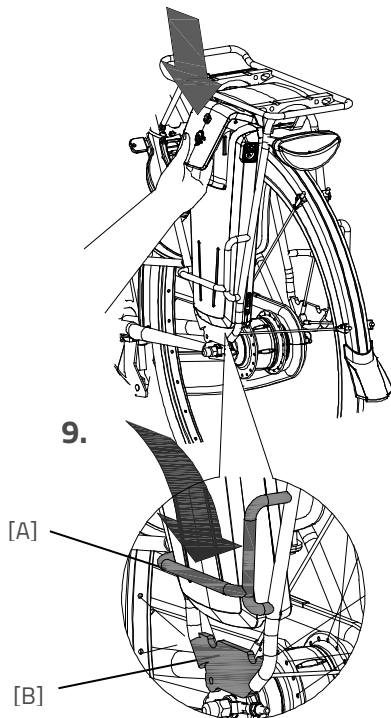

Charger:

LED indication	Status
Green	Standby
Red	Charging
Green	Battery full
Red, blinking	Safety: Polarity inversion; Short; Over temperature; Over power; Over voltage



It is better for the battery if it is charged regularly, rather than wait until it is completely drained. Never leave the bike with a drained battery!

Backup battery (optional)

The bike can be supplied with a second battery. To activate the second battery (when the first battery is empty), turn the switch under the luggage carrier to the side of the second battery.

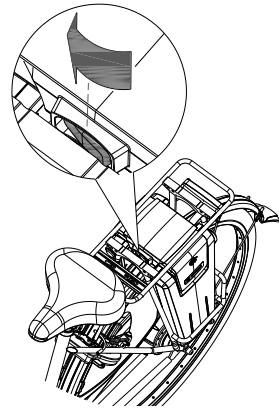

Battery Deep Sleep Mode

When the battery is nearly empty and has not been used for a week, the battery will enter deep sleep mode. In this mode the battery uses as little power as possible, to increase the lifespan of the battery.

When the battery is in deep sleep mode, it cannot be used. By pressing the button on the battery, the battery will be woken up from deep sleep mode, and it can be used again. It is recommended to first charge the battery before using it in that scenario.

Charging and maintenance tips for the battery

- Never leave the bike with an empty battery! We advise you charge the battery as soon as possible before it's totally empty.
- The best storage-charge of the battery is when three to five LED lights are lit.
- Check the battery every month in the winter. If fewer than three LED lights burn, recharge the battery.
- Preferably store and use the battery in environments of 5 to 20 °C. Avoid higher or lower temperatures.
- Do not charge the battery in sunlight and make sure that the battery is not charged at a temperature of less than 5 °C.
- Only use the charger indoors and in non-humid environments, the charger should *not* get wet.
- Only use the Van Raam supplied battery.
- Only charge the battery with the supplied charger!
- The battery housing and charger housing may never be opened! When there is a problem, contact your dealer.
- The Van Raam battery may not be revised due to serious safety risks and the incorrect functioning of the electric system as a whole.
- Don't drop the battery, this can cause external and internal damage.
- If your bicycle has a fault, the battery should be disconnected from the bicycle.



Keep in mind that your bike provides less support when it's cold (0°C and less) and the battery will discharge faster. Charging also takes more time at lower temperatures.



Every battery discharges automatically over time. This process is called self-discharge. A battery that is empty and not charged, will self-discharge and will be deep discharged. The battery can be permanently damaged during this process. In case of deep discharge, the warranty will be void.



Please note that any battery will wear over time. The wearing process of the battery is inevitable and depends on several factors, such as usage, number of charge cycles and the ambient temperature. Even if the battery is not used, its capacity will decrease. A worn battery can still be used, but please bear in mind that its charge level may decrease.

Possible malfunctions

- The system does not turn on:
 1. Make sure that the battery is properly attached.
 2. Check if the switch under the luggage carrier is pressed towards the side of the battery.
 3. Check the status of the battery. If it is empty, recharge the battery.
 4. If the above action does not help, contact your dealer.
- If the battery indicator LED lights on the display are flashing:

The motor may be overheated by continuous high load. For protection, the system will reduce the support.

 1. The system is in temperature-protection. You can continue cycling with reduced support.
 2. After cooling down, the normal support and indication will restore automatically.
- If the support LED lights on the display are flashing:

This indicates motor failure. You will need to contact your dealer.
- If a red LED light on the charger starts flashing, remove the plug from the mains outlet and do not longer use the charger. In this case, contact your dealer.

Charger Safety Measures

- Only charge Van Raam Li-Ion batteries with the included charger. Only connect the charger to a suitable power point (220-240 Volt AC 50-60 Hz). If the charger is not being used, unplug it from the socket and take the plug out of the battery.
- The charger may only be used by people who have read the information in this user manual and are familiar with the proper use of the charger. Keep the charger out of reach of children; do not let them play with it.
- The charger has been designed for use in a dust-free, dry, and ventilated environment. Do not expose the charger to water, heat sources, and direct sunlight. Keep the charger clean and dry.
- Do not charge batteries that feel hot to the touch. The battery may not be hotter than room temperature for charging. Stop charging if the battery becomes abnormally hot ($>40^{\circ}\text{C}$).

Please note! The charger may become hot during charging $> 50^{\circ}\text{C}$. First carefully feel if it is safe to touch the charger. This temperature can cause sensitivity or startle if it comes into contact with the skin.

- Do not use the charger if it is visibly damaged or modified. Do not repair the charger! Please contact Van Raam. Never open the charger yourself!
- While charging, please monitor the charger and the battery. Once the battery is full, remove the plug from the socket and the plug out of the battery.

Van Raam E-Bike App

The Van Raam bicycle app is a free smartphone app that you can use while cycling on your electric Van Raam bicycle.

What can you do with the Van Raam E-Bike App for your Smart E-Bike?

- Can be used as a luxury bicycle computer.
- View battery data.
- Receive battery advice.
- Change bike settings.
- Send SOS message with GPS location to a number of your choice.
- View cycled routes.
- View information about the bike.
- Location/Find my bike.
- Receive push notifications.

With the Van Raam App, a connection can be made with the smart display via Bluetooth connection. As soon as the smart display is ready to connect to the smartphone, the on/off button will briefly turn blue.

This app can be used as a luxury bicycle computer for Van Raam bicycles with pedal assistance and also contains many other extra functionalities. The dashboard on the app shows the current speed, total distance, trip meter, battery capacity and power consumption during the bike ride. For more cycling data, there is a details screen including average speed, maximum speed, total distance, power, battery voltage, pedalling power and pedalling frequency.

The Van Raam E-Bike App can be downloaded free of charge from the Google Play Store or Apple App Store.

For more information about the Van Raam App, you can visit the Van Raam website: www.vanraam.com.





From the 15th of July, 2020, all electric Van Raam bicycles will be delivered as Smart E-Bikes. You can recognize this by the large sticker with a yellow border on the battery. If you have a Smart E-Bike and you download the updated app, there are even more options. A Smart E-Bike collects technical data, such as battery voltages and electricity usage. This allows notifications to be sent if, for example, the battery power is getting low.

In addition, the Smart E-Bike also collects location data from the battery if you give permission for this as a user. Van Raam never collects personal data such as the GPS location without your permission. More information about the data that is collected can be found in the Privacy and Cookie statement on the Van Raam website.

Accessories

Depending on your order, you can use the accessories described below. Additional accessories are available from your dealer.

Detachable frame

The wheelchair can be disconnected from the bike part, so that you can use it for walking. Make sure the bike is on a flat surface before you detach the wheelchair-section.

To detach the wheelchair-section:

1. Use the tricycle's parking brake by squeezing the left-side brake [A] and securing the brake using the lever [B].
2. Remove the right handle (with gears) from the handlebar. Press the spring's small sphere to remove the handle from the handlebars. Also remove the parking brake from the steerer tube by lifting it straight up from the holder (this can take some strength).
3. Attach the handle with the brake lever to the carrier or any other suitable part.
4. Take the (extra) separate handle from the holder, which is situated behind the armrests of the passenger, and place this on the handlebar. Press the balls to slide the handle onto the handlebar. Make sure the balls click into the handle!
5. Fold the support wheel down so it falls into place.

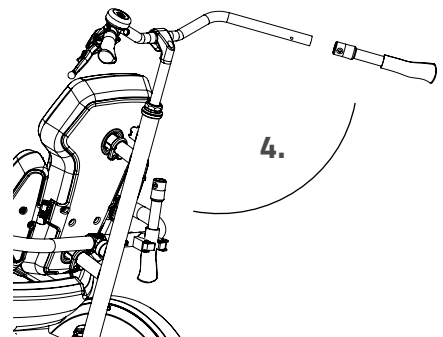
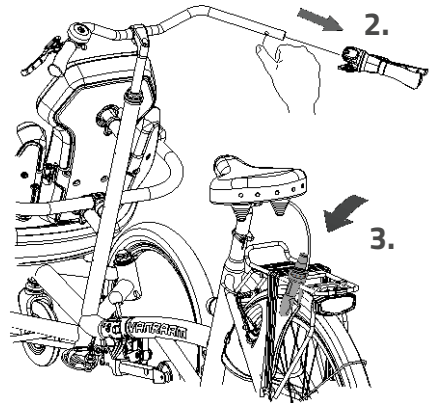
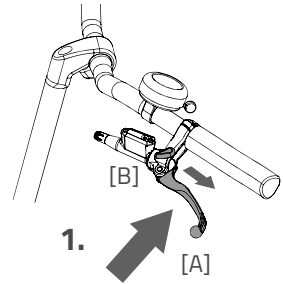

6. Remove the safety pin.
7. Hold the rear part (tricycle part) with one hand and then use your other hand to pull the lever backwards [A], allowing the tricycle to detach. The wheelchair section will tilt forward when the passenger is in it. Otherwise the wheelchair will rest on the supporting wheel.
8. Remove the tricycle part from the coupling. **Please note:** this part is heavy. Firmly hold the frame with both hands.
9. Place the rear part on the stand.

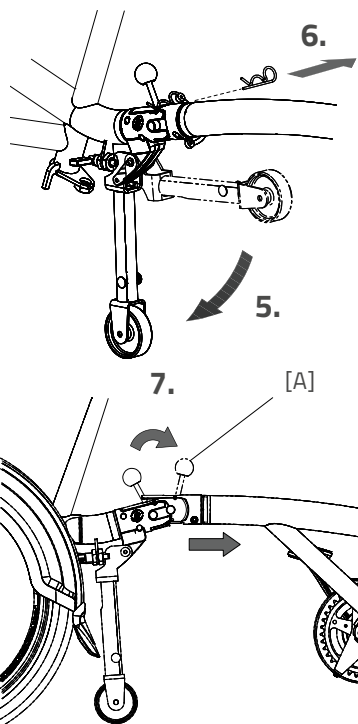

You can now walk with the wheelchair part.

Please note: the handlebars locks automatically.

In order to put the tricycle back together, simply follow these steps in reverse order.



Make sure the wheelchair rests on the front nose wheels when the back frame is attached. As soon as the frame has been attached, the wheelchair section can be tilted backwards due to which the connection snaps into place.

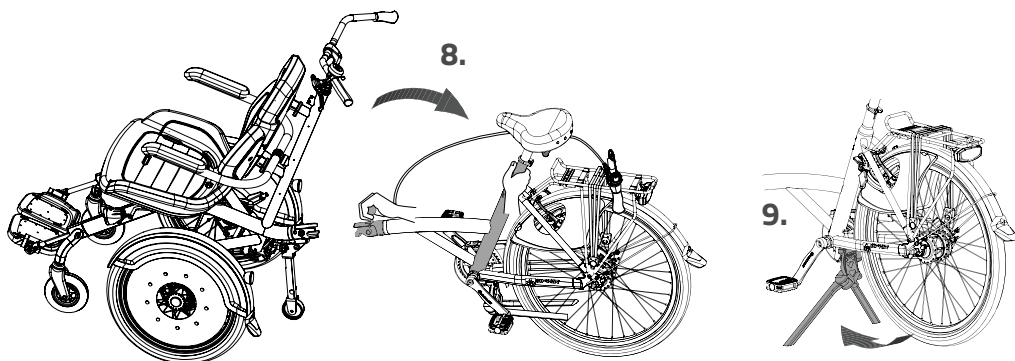

Headrest

To adjust the headrest:

1. Loosen the headrest's screw with an Allen key.
2. Set the headrest at the right height and tighten the screw.
3. Loosen the headrest's nuts with an open-end wrench.
4. The height, depth and angle can be adjusted simultaneously. Now tighten the nuts again.

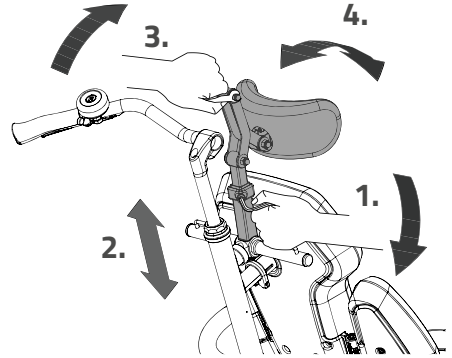

Please note: make sure the handlebars can easily move after setting up the headrest.

Adjustable seat width

The width of the chair can be fully tuned to the passenger.

To do this:

1. Loosen the two nuts on the back of the pillow with an open-end wrench.
2. Slide the supports so that they fit the body of the passenger. Tighten the nuts

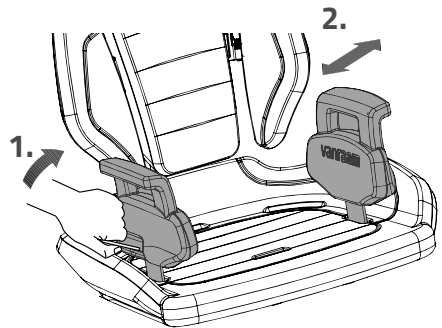

Foot fixation

The feet of the passenger can be fixed by means of two belts. When getting on and off, the footplates can be folded upwards. The footrest can be folded up by pressing the tab [A]. The footplates automatically lock themselves when folded back.

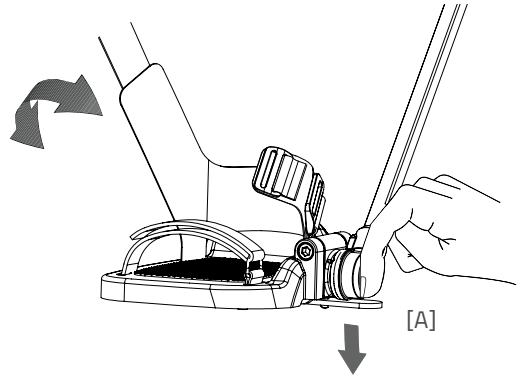

Four- and five-point belt

Turn the belt around the body and attach it to the clamp. You can release the belt again by pressing the red button.

In order to use the five-point belt, the eye of the waist belt must be inserted through one side of the hip belt.

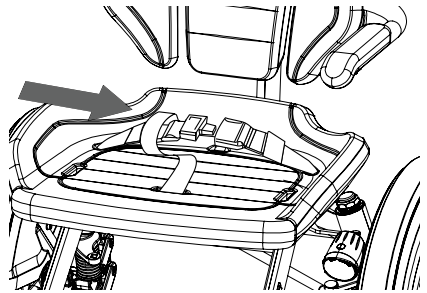

Four- and five-point
belt for children



Four- and five-point
belt for adults



The children's belts go through the middle of the backrest. The adult belts go over the chair.

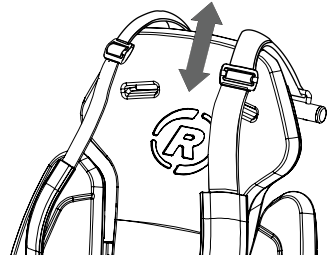

Adjust the seatbelt clamps so the seatbelt is adjusted to the passenger's body.

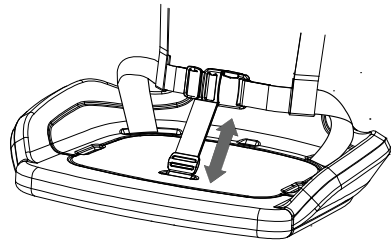

Technical specifications

Length (cm)	214
Width (cm)	76
Height (cm)	120
Mounting Height (cm)	45
Inseam Size (cm)	80-95
Front Wheel	20"
Rear Wheel	26"
Weight (kg)	approx 58
Max. Load Carrier (kg)	20
Max. Weight Rider (kg)	120
Max. Weight Passenger (kg)	120
Brakes, front	Disc Brakes
Rear Brakes	Cantilever / Rim Brakes

Maintenance and adjustments by owner

Below are some instructions for maintenance and adjustments that you can perform on a regular basis. This ensures an optimum condition of your bike.

Cleaning

The frame of the tricycle can be cleaned with a damp cloth. For dirty spots it is recommended to use a mild detergent.

The wheels can be cleaned with a damp brush with plastic bristles (not a wire brush!). The saddle, handlebars and seat can be cleaned with mild soap and water.



Never use a high pressure or steam cleaner!

The right lubricant

The chain should be cleaned and maintained regularly (approx. once every three months). Only use special chain grease or Teflon spray. This is the only way to ensure that the chain moves smoothly, remains water-repellent and does not rust.

1. Clean the chain with a cloth.
2. Treat the chain with grease or spray.
3. Remove all abundant lubricants with a rag.

Never treat any of the other parts with lubricant.

Inspection of the tricycle

It is necessary to have the bike inspected by a dealer at least once a year. This in order to extend your warranty claim. Please use the 'Service, Maintenance and Modifications Form' at the back of this manual when doing so. The first maintenance will be performed after the first 200 kilometres or two months.

In case of failure or defects, **immediately** bring the tricycle to the dealer for repair.

The replacement of safety-related components (i.e. frame, brakes, lights, handlebars, front fork and drive) must be done by your dealer.

If you choose to replace components by yourself, you will be liable for any damage or injury caused by improperly installed components.

Only use **original** Van Raam spare parts. You can purchase these from your dealer. Upon request, the dealer will provide the necessary information for repair and maintenance.

Repair and maintenance by your dealer

During the maintenance session, check the brakes, wheels, lights, chain tension and spokes. Also check the tread depth of the tyres. This must be at least one millimetre. Worn tyres or defective parts must be replaced. Also check the operation of the parking brake. When the parking brake is active, the tricycle with rider may not move. Finally, the front suspension must be checked. First check whether the bolts are secure. Subsequently check whether the spring does not allow any vertical play. If this is the case, it is necessary to take a closer look at this component.

Inspection of the rims

Due to the interplay between both the brake and rims, both the condition of the brake lining and rims is important. For this reason, the rims must be regularly inspected (e.g. when pumping the tyre). The presence of fine cracks in the rim at the spoke nipples or deformation of the rim during elevated air pressure in the tyre, indicate greater wear and tear. In that case the rim must be replaced. If not, this may negatively impact the operation of the brakes or may even cause a break in the rim with all sorts of dangerous consequences.

Repairs, maintenance and modifications may only be performed with original Van Raam parts.

Adjustments by dealer

The correct tension of the chains

Several chains are present on the tricycle. These must have enough room for movement. Without any real effort, the chain must be able to be moved about half a centimetre up and down.

In order to keep tension on the chain, the rear wheel axis can be adjusted. Follow the instructions below:

1. Slightly loosen the nuts on the rear wheel axis, allowing the rear wheel to move back and forth.
2. Tighten the screws on the two chain tensioners, making the rear wheel move backwards and tightening the chain. Do this in such a way that the chain has some room to move, as previously indicated.
3. At the same time, make sure the wheel is straight and located in the middle of the frame. Not to the left or right. See figure [A].
4. Lightly tighten the nuts of the rear wheel axis.
5. Make sure the tension on the chain is adequate and that the wheel is attached straight to the frame.
6. Now firmly tighten the nuts.

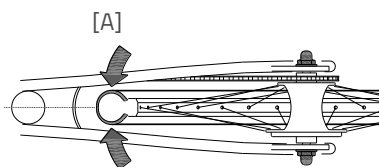
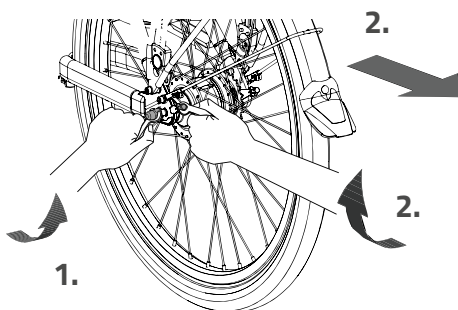

Setting the steering

In order to realise optimal steering behaviour and minimal tyre wear, the steering must be set correctly.

1. Loosen the left and right nuts of the steering shaft [A].
Please note! This is a nut with a left wire and a nut with a right wire.
2. Subsequently turn the steering shaft to adjust the tracking of the wheels. The wheels must be set parallel.
3. Tighten the nuts of the steering shaft again.
4. Loosen the two nuts of the steering shaft [B].
Please note! This is a nut with a left wire and a nut with a right wire.
5. Make sure the steering stop is in the middle of the steering plate [C]. In case of a dividable frame, the handlebar is automatically fixed in this position when the wheelchair section is disconnected.
6. Subsequently move the steering shaft to ensure that the wheels face straight ahead when the steering stop is in the middle of the steering plate.
7. Tighten the nuts of the steering shaft again.
8. Finally point the handlebar straight ahead. Make sure the wheels also face straight ahead at that moment.
9. Check whether the tricycle easily drives straight ahead on the tyres, without resistance and friction.

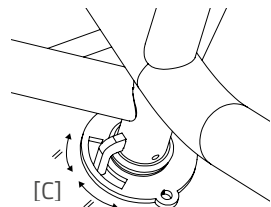
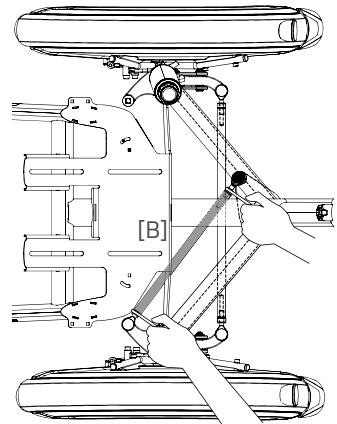
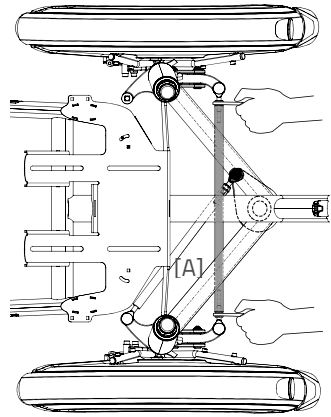

Handle Bar Lock on Detachable Frame

It is important that the handlebar lock is set up correctly. The locking bolt ensures that the handlebars are locked when the rear frame is detached from the front frame.

Check if the handle bar lock has been set up correctly:

1. When the front and rear frame are linked, check if the bracket [A] is not under tension and has minimal vertical movement. Also check if the locking bolt [B] is released.
2. When the front and rear frame are detached, check if the locking bolt sticks into the plate [C] by at least 2 mm.

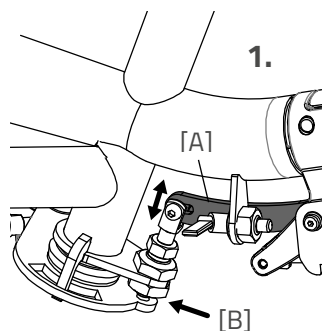

If this deviates, loosen the two nuts [D] using a nut spanner and adjust the locking bolt in the correct manner as described above.

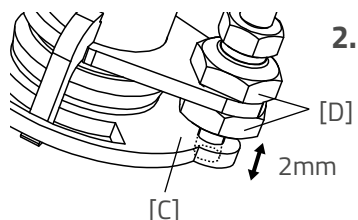

Disposal

If you want to dispose your tricycle, contact your dealer. You can also contact the local waste disposal company. They will dispose the tricycle according to the regulations of your town.

Recycling the Battery

If your battery is defective or if you are no longer using it, you must have it recycled. Please contact your dealer. They are responsible for complying with the recycling obligation. Ask them about the conditions or view the rules regarding recycling in your place of residence/country.

Handover/sale to a new owner

When you hand over your tricycle to a new owner it is important that you also hand over all necessary technical documentation and spare keys, so that the new owner can use the tricycle safely.

Guarantee

The guarantee is valid for all faults in the product, which are proven to be caused by material or manufacturing error.

We give a guarantee of five years on the frame and the front fork. For all accessories and other parts (except wear parts) we provide a two year guarantee, as legally regulated. The guarantee only applies for normal use and maintenance of the tricycle, as described in this manual.

Beware!

The guarantee as well as the product liability in general expires if the instructions stated in this manual are not followed. This is also the case if unauthorized maintenance is carried out or if technical changes or additions are made with non-original Van Raam parts without permission of Van Raam. The original CE certification will become nul-and-void if modifications are done by third parties. The absence of the certification can lead to problems in insuring your bike, and for any loss or incurred.

Frame number

The frame number is printed on the sticker. This sticker is located on the frame, see the image below.

Example sticker:



Position of sticker:



Behind the seat tube

Service record, maintenance, modifications and warranty claims

To maintain warranty on the Van Raam tricycle, follow this service schedule.

Service:	Carried out (date):	Signature dealer:
Service after the first 200 KM or two months.		
Service 1 year after delivery.		
Service 2 year after delivery.		
Service 3 year after delivery.		
Service 4 year after delivery.		
Service 5 year after delivery.		

Even after five years, we advise you to give your bike annual service. Passing by the service after five years will have no further effect on warranty claim because it expires for certain parts after five years.

Modifications to the bike

The following items are changed to the bike:

Changed:

Date:

Carried out:

Beware! Please note that if changes are made by a non-authorized Van Raam dealer or no original Van Raam parts or options are used, warranty may void.

Delivery and service form

Congratulations on your purchase of your Van Raam tricycle. This bike is produced with utmost care. To guarantee the quality as much as possible Van Raam produces the cycles according to the ISO 9001:2015 quality standards. Van Raam has been certified by DNV GL Business Assurance B.V.

You will especially enjoy your Van Raam bike when the bike is adjusted to your specifications and when the instructions in the user manual are followed. Pay special attention on the service intervals who specified in the manual of the bike.

To claim warranty and service you should always fill out this form, at least at delivery and service. This signed form declares that the end user had an instruction on the operation of the tricycle, that the tricycle is adjusted to the specifications of the end user and that the user manual is received.

Fill out when the tricycle is delivered

Type Van Raam tricycle:	
Frame number:	
Key number:	
Delivered to:	
By dealer:	
Place:	
Date:	
Signature user bike:	Signature dealer:
When available, stamp dealer:	